

Section II.

TM 9-2320-280-24P-1

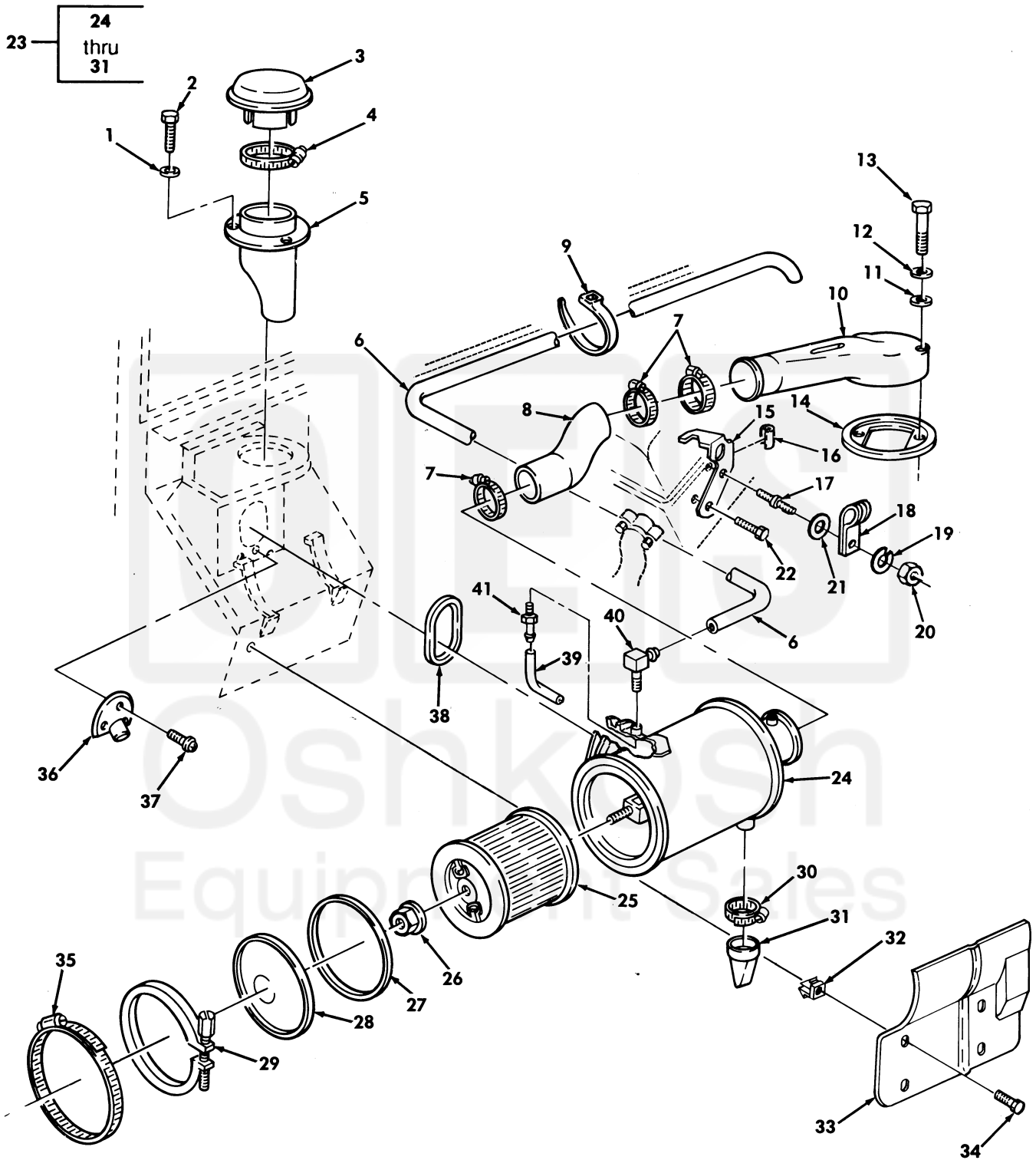

Figure 12. Air Cleaner, Air Horn, and Related Parts.

SECTION II		TM9-2320-280-24P				
(1)	(2)	(3)	(4)	(5)	(6)	(7)
ITEM NO	SMR CODE	NSN	CAGEC	PART NUMBER	DESCRIPTION AND USABLE ON CODES(UOC)	QTY
GROUP 0304 AIR CLEANER						
FIG. 12 AIR CLEANER,AIR HORN,AND RELATED PARTS						
1	PAOZZ	5310008094058	96906	MS27183-10	WASHER,FLAT.....	3
2	PAOZZ	5305011628512	24617	9421073	SCREW,TAPPING.....	3
3	PAOZZ	2940011891809	78940	F-6D9K090B	CAP,AIR CLEANER INT.....	1
4	PAOZZ	4730003599487	66295	C72P	CLAMP,HOSE.....	1
5	PFOZZ	2940011883224	19207	12338373	SHIELD ASSEMBLY.....	1
6	MOOZZ		34623	CPR104420-1-26	TUBE,METALLIC MAKE FROM TUBING,P/N CPR104420-1,26 INCHES LONG.....	1
					UOC:A14,A26,A27,B18,H14,H18,H26,H27, H28	
6	MOOZZ		19207	CPR104420-1-28	TUBE,METALLIC MAKE FROM TUBING,P/N CPR104420-1,28 INCHES LONG.....	1
					UOC:AVY,A11,A13,A15,A20,A24,A25,BVY, B15,B16,B17,B20,B24,B25,C17,HVY,H11, H13,H15,H16,H17,H20,H21,H24,H25,MMM, NNN	
7	PAOZZ	4730011890871	76599	H68SS	CLAMP,HOSE.....	3
8	PAOZZ	4720011858152	19207	12338380	HOSE,PREFORMED.....	1
					UOC:AVY,A11,A13,A14,A20,A24,A25,A26, A27,BVY,B16,B17,B18,B20,B24,B25,C17, HVY,H11,H13,H14,H16,H17,H18,H20,H21, H24,H25,H26,H27,H28,MMM,NNN	
8	PAOZZ	4720012037789	34623	5584588	HOSE,PREFORMED.....	1
					UOC:A15,B15,H15	
9	PAOZZ	5975000742072	96906	MS3367-1-9	STRAP,TIEDOWN,ELECT.....	1
10	PAOZZ	4710012781053	34623	5584559	TUBE,AIR HORN INTAK.....	1
11	PAOZZ	5310011857214	19207	12339052	WASHER,FLAT 5/16.....	2
12	PAOZZ	5310011328275	24617	9418924	WASHER,FLAT 5/16.....	2
13	PAOZZ	5306002258511	96906	MS90725-47	BOLT,MACHINE 5/16-18 X 3.75.....	2
14	PAOZZ	5330012461822	19207	12338382	GASKET.....	1
15	PFOZZ	5340011899861	34623	5590657	BRACE,CORNER.....	1
16	PAOZZ	2590014710236	19207	12339902-13	PROTECTOR,PAINT.....	1
17	PAOZZ	5307011509538	15946	22515630	STUD,SHOULDERED 10-1.5 X 20 MM.....	1
18	PAOZZ	5340001519651	96906	MS21333-129	CLAMP,LOOP.....	1
19	PAFZZ	5310012067306	7X677	11500207	WASHER,LOCK M10.....	1
20	PAOZZ	5310011430512	73342	29520052	NUT M10.....	1
21	PAOZZ	5310012101587	7X677	11500256	WASHER,FLAT #10.....	1
22	PAOZZ	5306011589917	1FH08	DIN933M10X20	BOLT,MACHINE 10-1.5 X 20MM.....	1
23	PAOOO	2940011885117	78940	L-111D30	AIR CLEANER,INTAKE.....	1
24	XAOZZ		78940	L-111DR30-L	.BODY ASSEMBLY.....	1
25	PAOZZ	2940011883776	78940	W-250D53	.FILTER ELEMENT,INTA.....	1
26	PAOZZ	5310012115037	78940	0-952A59	.NUT,PLAIN,HEXAGON 5/16-18.....	1
27	PAOZZ	5330014522474	34623	12342872	.GASKET.....	1
28	PAOZZ	2940011883387	78940	L-563C170	.COVER,AIR CLEANER.....	1
29	PAOZZ	5340011900402	78940	L-223C24	.CLAMP,LOOP.....	1
30	PAOZZ	4730012574905	39428	5416K25	.CLAMP,HOSE.....	1
31	PAOZZ	2520010241273	78940	L-638C2GS	.BOOT,DUST AND MOIST.....	1
32	PAOZZ	5340012088688	34623	5585094	SHIELD,EXPANSION.....	4
33	PAOZZ	2540011964726	19207	12338863	SHIELD,AIR CLEANER.....	1

Current part is item (3) on diagram. Available at [www.oshkoshequipment.com](http://www.oshkoshequipment.com)

SECTION II		TM9-2320-280-24P				
(1)	(2)	(3)	(4)	(5)	(6)	(7)
ITEM	SMR			PART		
NO	CODE	NSN	CAGEC	NUMBER	DESCRIPTION AND USABLE ON CODES(UC)	QTY
34	PAOZZ	5305000581082	96906	MS51861-34	SCREW,TAPPING #10-16 X 1/2.....	4
35	PAOZZ	4730012105785	7Z588	HTM-1200	CLAMP,HOSE.....	3
36	PFOZZ	5342011877029	19207	12338842	BRACKET,TUBE,DRAIN.....	1
37	PAOZZ	5305002267237	80205	MS16995-78	SCREW,CAP,SOCKET HE #8-18 X 3/8....	3
38	PAOZZ	5330011880911	19207	12338379	GASKET.....	1
39	PFOZZ	4720012145757	19207	12340799	TUBING,NONMETALLIC.....	1
40	PAOZZ	4730010707680	01989	1069X4	ELBOW,PIPE TO HOSE.....	1
41	PAOZZ	4730011855348	01989	1068X4	ADAPTER,STRAIGHT,PI.....	1

END OF FIGURE



Current part is item (3) on diagram. Available at [www.oshkoshequipment.com](http://www.oshkoshequipment.com)